

FITTING INSTRUCTION

Clamp mark in acc. with		Cables joining
ISO	PN	
1	L	Left directional lights
2	+	Rear fog lights
3	31	Ground
4	R	Right directional lights
5	58R	Right side parking lights
6	54	Stoptlights
7	58L	Left side parking lights

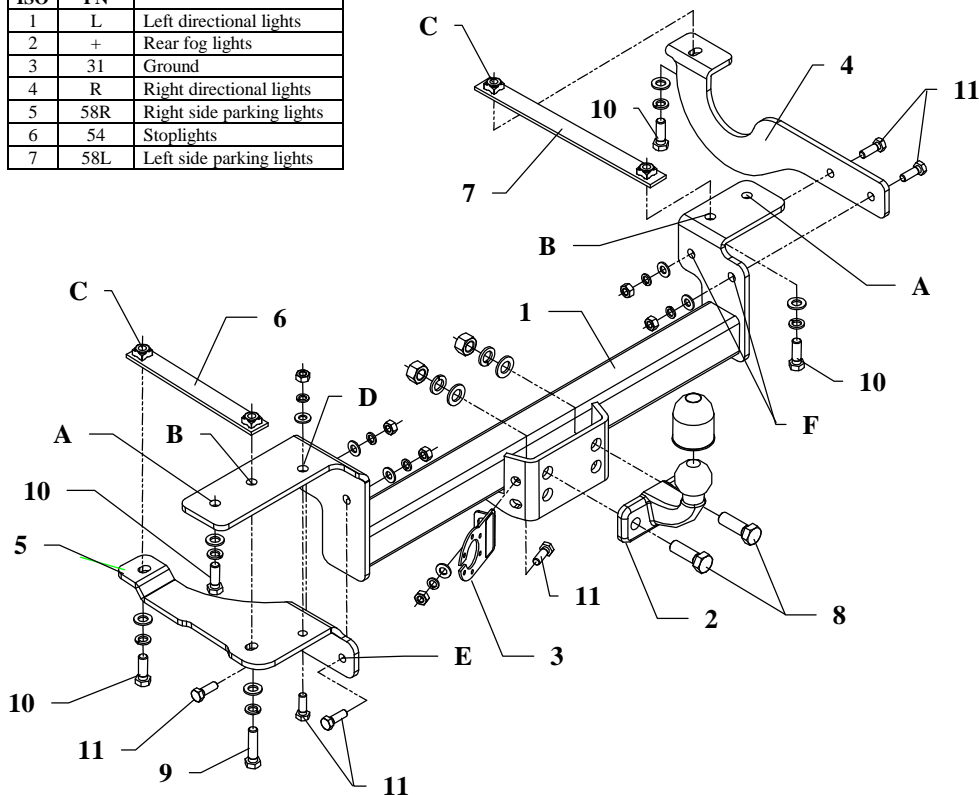

This towing hitch is designed to assembly in following cars:
SUZUKI SAMURAI, produced since 1996, catalogue number **W06** and is prepared to tow trailers max total weight up to **1300 kg** and max vertical mass **75 kg**.

From manufacturer

Thank you for buying our product. Their reliability has been confirmed in many tests. Reliability of towing hitch depends also on correct assembly and right operation. For this reasons we kindly ask to read carefully this instruction and apply to hints.

The towing hitch should be installed in points described by a car producer.

The instruction of the assembly

1. Disassemble rear bumper together with lights (to get access to chassis members).
2. Disassemble original towing eye (keep one bolt for future installation).
3. Put main bar of the towbar (pos. 1) underneath to chassis frame and through holes pos. A and holes existing in frame's handle fix on the left side by bolt M12x35mm (pos. 10) and on the right side by bolt disassembled from original towing eye (see point 2).
4. Put suitable fish-plates with nuts (pos. 6 and 7) at points B, mark holes pos. C (in axis of the frame) and next drill holes using bit $\varnothing 13\text{mm}$.
5. On the left side put fish-plate with nuts I (pos. 6) into the chassis frame and put left bracket (pos. 5) to main bar and fix by bolt M12x50mm (pos. 9) through hole pos. B.
6. Fix left bracket through holes pos. D and E by bolts M10x30mm (pos. 11) and then through hole pos. C by bolt M12x35mm (pos. 10).
7. On the right side put fish-plate with nuts II (pos. 7) and fix with main bar through hole pos. B using bolt M12x35mm (pos. 10).
8. Put right bracket (pos. 4) to main bar and through holes pos. F fix using bolts M10x30mm (pos. 11) and then fix using bolt M12x35mm (pos. 10) through hole C with chassis member.
9. Assemble bumper to towing hitch using original bolts and nuts.
10. Fix tow-ball (pos. 2) using bolts M16x50mm (pos. 8) from equipment.
11. Fix socket plate (pos. 3) by bolt M10x30mm (pos. 411 as shown on the figure).
12. Tighten all bolts according to the torque shown in the table.
13. Connect electric wires of 7-poles socket according to the instruction of the car. (Recommend to make at authorized service station).
14. Complete paint layer damaged during installation.

Torque settings for nuts and bolts (8,8):

M6 - 11 Nm	M8 - 25 Nm	M10 - 50 Nm
M12 - 87 Nm	M14 - 138 Nm	M16 - 210 Nm











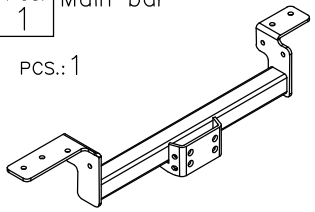
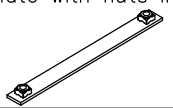

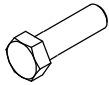

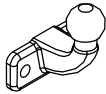
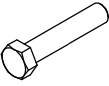
NOTE

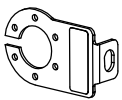
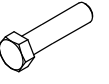
After installation of the towing hitch you should get adequate note in registration book (at authorised service station).The car should be equipped with:

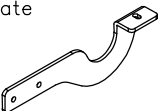
- Indicators
- Tow mirrors

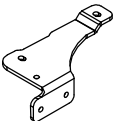
Check all bolts and nuts after **1000 km** of exploitation. The ball of the towing hitch must be always kept clear and conserve with a grease.

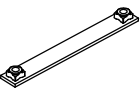
Part list:

Pos. 1 Main bar PCS.: 1 	Pos. 7 Fish-plate with nuts II pcs.: 1 	Pos. 14 Plain washer ø10,5mm PCS.: 6 
	Pos. 8 Bolt 8,8 B M16x50mm PCS.: 2 	Pos. 15 Spring washer ø16,3mm PCS.: 2 
Pos. 2 Tow ball pcs.: 1 	Pos. 9 Bolt 8,8 B M12x50mm PCS.: 1 	Pos. 16 Spring washer ø12,2mm PCS.: 5 
Pos. 3 Socket plate pcs.: 1 	Pos. 10 Bolt 8,8 B M12x35mm PCS.: 4 	Pos. 17 Spring washer ø10,2mm PCS.: 6 
Pos. 4 Socket plate pcs.: 1 	Pos. 11 Bolt 8,8 B M10x30mm PCS.: 6 	Pos. 18 Nut 8 B M16 PCS.: 2 
Pos. 5 Left bracket pcs.: 1 	Pos. 12 Plain washer ø17mm PCS.: 2 	Pos. 19 Nut 8 B M12 PCS.: 6 
Pos. 6 Fish-plate with nuts I pcs.: 1 	Pos. 13 Plain washer ø13mm PCS.: 5 	Pos. 20 Ball cover PCS.: 1 



PPUH AUTO-HAK S.J.

Produkcja Haków Holowniczych
Henryk & Zbigniew Nejman
76-200 SŁUPSK ul. Słoneczna 16K
tel/fax (059) 8-414-414; 8-414-413
E-mail: office@autohak.com.pl
www.autohak.com.pl

Towing hitch (without electrical set)

Class: **A50-X** Cat. no. **W06**
Designed for:
Manufacturer: **SUZUKI**
Model: **SAMURAI**
produced since 1996

Technical data:
D-value: 6,5 kN
maximum trailer weight: **1300 kg**
maximum vertical cup mass: **75 kg**

Approval number according to Directive 94/20/EC: e20*94/20*0625*00

Foreword

This towing hitch is designed according to rules of safety traffic regulations. The towing hitch is a safety component and can be install only by qualified personnel. Any alteration or conversion of the towing hitch is prohibited and would lead to cancellation of design certification. Remove insulating compound and underseal from vehicle (if present) in the areas of the matting surfaces of the towing hitch. The vehicle manufacturer's specifications regarding trailer load and max. vertical cup mass are decisive for driving whereat values for the towing hitch cannot be exceeded.

D-value formula:

$$\frac{\text{Max trailer weight [kg]} \times \text{Max vehicle weight [kg]}}{\text{Max trailer weight [kg]} + \text{Max vehicle weight [kg]}} \times \frac{9,81}{1000} = D \text{ [kN]}$$